

---

D i g i g r a m

---

# NCX

## User's Manual



## ■ INFORMATION FOR THE USER

---

This device complies with part 15 of FCC rules.

Operation is subject to the following two conditions: (1) This device may not cause harmful interference, and (2) This device must accept any interference received, including interference that may cause undesired operation.

This equipment has been tested and found to comply with the limits for a CLASS B digital device, pursuant to Part 15 of the FCC Rules. These limits are designed to provide reasonable protection against harmful interference in a residential installation. This equipment generates, uses, and can radiate radio frequency energy and, if not installed and used in accordance with the instructions contained in this data sheet, may cause harmful interference to radio and television communications. However, there is no guarantee that interference will not occur in a particular installation.

If this equipment does cause harmful interference to radio or television reception, which can be determined by turning the equipment off and on, the user is encouraged to try to correct the interference by one or more of the following measures:

- reorient or relocate the receiving antenna
- increase the separation between the equipment and the receiver
- connect the equipment into an outlet on a circuit different from that of the receiver
- consult the dealer or an experienced audio television technician.

*NOTE: Connecting this device to peripheral devices that do not comply with CLASS B requirements or using an unshielded peripheral data cable could also result in harmful interference to radio or television reception. The user is cautioned that any changes or modifications not expressly approved by the party responsible for compliance could void the user's authority to operate this equipment. To ensure that the use of this product does not contribute to interference, it is necessary to use shielded I/O cables.*

## ■ IMPORTANT NOTICE

This device has been tested and found to comply with the following standards :

- International : CISPR22 Class B.
- Europe : EMC 89/336/CEE (1992) specifications.
- United States : FCC Rules-Part 15-Class B (digital device).

In order to guarantee compliance with the above standards in an installation, the following must be done:

- Connectors must have a conductive shell.
- Cables must be shielded and their shield must be tightly connected to the shell of the connectors.

### ■ AVAILABLE OPTIONS :

NCX can be delivered with one of the following options

- NCX 200 : 2 mono outputs
- NCX 400 : 4 balanced mono outputs
- NCX 040 : 4 balanced mono inputs (with mic/line level selection)
- NCX 220 : 2 mono inputs (with mic/line level selection) and 2 mono outputs

### ■ OVERVIEW

---

- Independent device exchanging digital sound through Ethernet 803.3 network
- 10 BASE-T Ethernet interface.
- 2 or 4 analog mono outputs and 1 stereo headphone output (depending on option).
- 4 analog mono inputs (depending on option).
- 7 general purpose inputs/outputs.
- 2 general purpose RS232 links.

### ■ SOFTWARE REQUIREMENTS

---

- V99.2 np SDK or higher (no PCX cards managed)
- V5.40 np SDK or higher (PCX cards also managed)

### ■ HARDWARE INSTALLATION

---

- Install the NCX box in the suitable place,
- Connect the audio input/output,
- Connect the network cable (RJ45)
- Connect the power supply to the NCX box (mini DIN plug)
- Plug the power supply into the AC supply socket.

### ■ SOFTWARE INSTALLATION (np DRIVER ONLY)

---

No driver floppy disk is delivered with the NCX.

Please ask your supplier for an updated driver or download it from the Digigram Web site.

Make sure that the driver has been approved by your supplier. Your supplier's application may request the use of a specific driver.

Please refer to the installation documentation which is delivered with the driver. It details the installation procedure to follow under Windows 95/98 and Windows NT.

## ■ DETAILED FEATURES

### Audio outputs (when available)

#### Analog outputs

- 2 or 4 balanced analog outputs (available on SubD15)
- 2 unbalanced analog outputs (on RCA or 3.5mm stereo jack)
- output impedance < 100 ž.
- maximum level : +10dBu on balanced outputs - +4dBu on unbalanced outputs (software adjustable)
- output level adjustment : down to - 91.5dBu by 0.5dB steps.
- 24 bits digital to analog converters (128 x oversampling delta-sigma converters).
- Sampling frequencies : 8, 11.025, 16, 22.05, 24, 32, 44.1, 48 kHz

#### Headphone output

- 3.5mm stereo jack
- Source impedance : 100 ž

### Audio inputs (when available)

#### Analog inputs

- 2 or 4 balanced analog inputs (available on SubD15)
- output impedance > 10k ž.
- maximum level : +10dBu (line level) or - 26dBu (mic 1 level) or - 37dBu (mic 2 level)
- 24 bits digital to analog converters (128 x oversampling delta-sigma converters).
- Sampling frequencies : 8, 11.025, 16, 22.05, 24, 32, 44.1, 48 kHz

### Analog performances

Characteristics are measured at 48 kHz sampling frequency, in linear (PCM) mode.

- Signal / Noise ratio (un-weighted) : better than 94 dB.
- Total Harmonic Distortion + Noise (un-weighted): better than - 85 dB (0.0056%) with 1kHz signal, -2dBFS.
- Frequency response (20Hz/20kHz) :  $\pm 0.1$  dB .
- Difference in phase (20Hz/20kHz) :  $0.2^\circ / 2^\circ$
- Crosstalk at 1kHz : better than - 95 dB

### Physical

- Cabinet dimensions : 175mm x 175mm x 45mm
- The cabinet includes a metallic shell

### Power consumption (typical)

- + 5V input : 1.5A
- AC power : 25VA

### Environmental

#### Temperature:

- Storage :  $-5^\circ\text{C} / +70^\circ\text{C}$
- Operating :  $0^\circ\text{C} / +50^\circ\text{C}$

#### Humidity (non condensing):

- Storage : 0% / 95%
- Operating : 5% / 90%

### **Network**

NCX appliance includes a standard Ethernet 10 BASE-T interface. Wiring of the network must obey to standard rules.

If more than 2 NCX appliances are connected to the same sound server, it is mandatory to use a 100 BASE-T Ethernet adapter on the server side and a 10/100 BASE-T hub or preferably a 10/100 BASE-T switch.

### **Processing**

Processing power is given by the internal DSP 56303 associated with a micro-controller managing data exchange over Ethernet port.

### **Miscellaneous**

#### **General Purpose Interface**

- 7 TTL I/O user definable.

#### **Serial Interface**

- 2 independent RS232 receiver/transmitter pairs

■ SCHEMATIC DIAGRAM

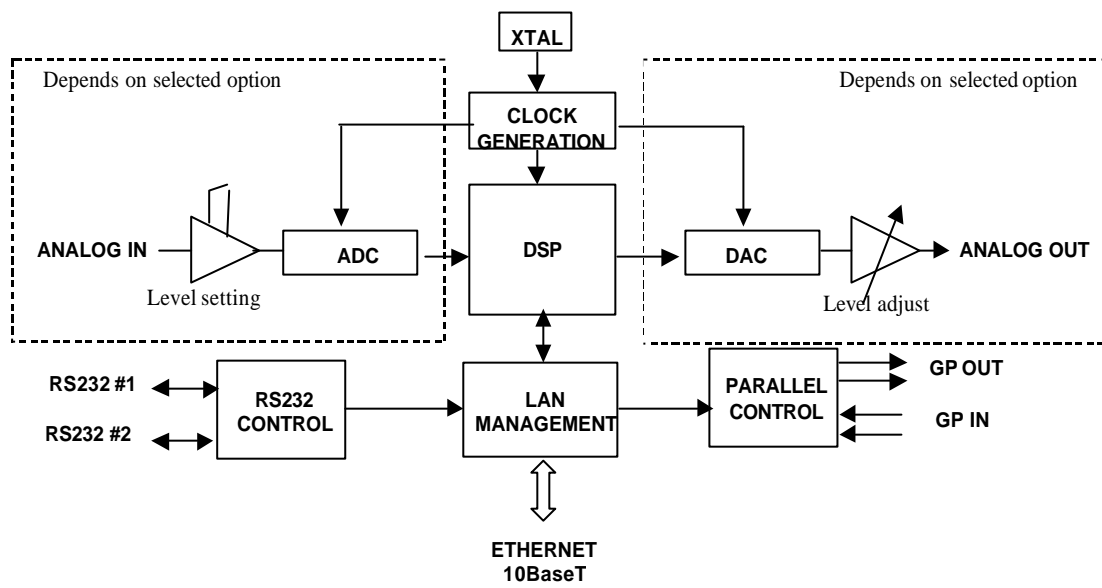

NOTE : Depending on the selected option, only analog input or analog output may exist.

# NCX

## User's Manual

### Front panel



Status LEDs      R : Red : Power ON  
                           G : Green : DSP activity  
                           Y : Yellow : LAN activity

J1 - Parallel I/O connector. (SubD 15 female; front side)  
 To use this connector, please refer to programming manual

pin #	Signal	pin #	Signal
1	GND	9	reserved
2	VCC (5V/100mA max.)	10	PIO31
3	PIO30	11	PIO4
4	reserved	12	PIO5
5	#RESET to ext. system	13	PIO2
6	PIO17	14	PIO25
7	reserved	15	reserved
8	GND		

J2 - Serial I/O RS232 connector.  
 (SubD 9, male; front side)

pin #	Signal	pin #	Signal
1	nc	6	nc
2	RXD1	7	nc
3	TXD1	8	RXD0
4	nc	9	TXD0
5	GND		

NOTA : TXD1 and RXD1 are standard RS232 TX/RX pins

J3 - Stereo Headphone 3.5mm Jack connector : Stereo channel #1 output. Delivers the same signal as outputs OUT1 ( L ) and OUT2 ( R ), with a headphone adaptor.

### Rear panel



J4 - Analog Audio connector.  
 (SubD 15, female; back side)

pin #	NCX 200 2 outputs	NCX 400 4 outputs	NCX 040 4 inputs	NCX 220 2 ins - 2 outs
1	OUT2 + ( R )	OUT2 + ( R1 )	IN4 + ( R2 )	OUT2 + ( R )
2	GND	GND	GND	GND
3	OUT1 - ( L )	OUT1 - ( L1 )	IN3 - ( L2 )	OUT1 - ( L )
4	GND	GND	GND	GND
5	GND	GND	GND	GND
6	reserved	OUT4 - ( R2 )	IN2 - ( R1 )	IN2 - ( R )
7	reserved	OUT3 + ( L2 )	IN1 + ( L1 )	IN1 + ( L )
8	GND	GND	GND	GND
9	OUT2 - ( R )	OUT2 - ( R1 )	IN4 - ( R2 )	OUT2 - ( R )
10	OUT1 + ( L )	OUT1 + ( L1 )	IN3 + ( L2 )	OUT1 + ( L )
11	GND	GND	GND	GND
12	GND	GND	GND	GND
13	reserved	OUT4 + ( R2 )	IN2 + ( L1 )	IN2 + ( L )
14	GND	GND	GND	GND
15	reserved	OUT3 - ( L2 )	IN1 - ( R1 )	IN1 - ( R )

J5, J6 - RCA (Phono) Plugs

Stereo output #1, delivers the same signal as outputs OUT1 ( L ) and OUT2 ( R ), but in unbalanced mode.

#### Available options

- Analog breakout cable for NCX200
- Analog breakout cable for NCX400
- Analog breakout cable for NCX040
- Analog breakout cable for NCX220



**Digigram S.A France**  
E-mail : [info@digigram.com](mailto:info@digigram.com)

**Digigram Inc. USA**  
E-mail : [input@digigram.com](mailto:input@digigram.com)

**Digigram Asia Pte Ltd**  
E-mail : [info\\_asia@digigram.com](mailto:info_asia@digigram.com)

[www.digigram.com](http://www.digigram.com)